

PRESENTACIÓN

ITEM	DESCRIPCIÓN	QTY	MATERIAL	No. PLANO
1	CABEZA DE PISTÓN	1	ACERO AL CARBÓN 10/18	001
1	BUJE DE BRONCE	1	BRONCE SAE 64	001

INFORMACIÓN ADICIONAL

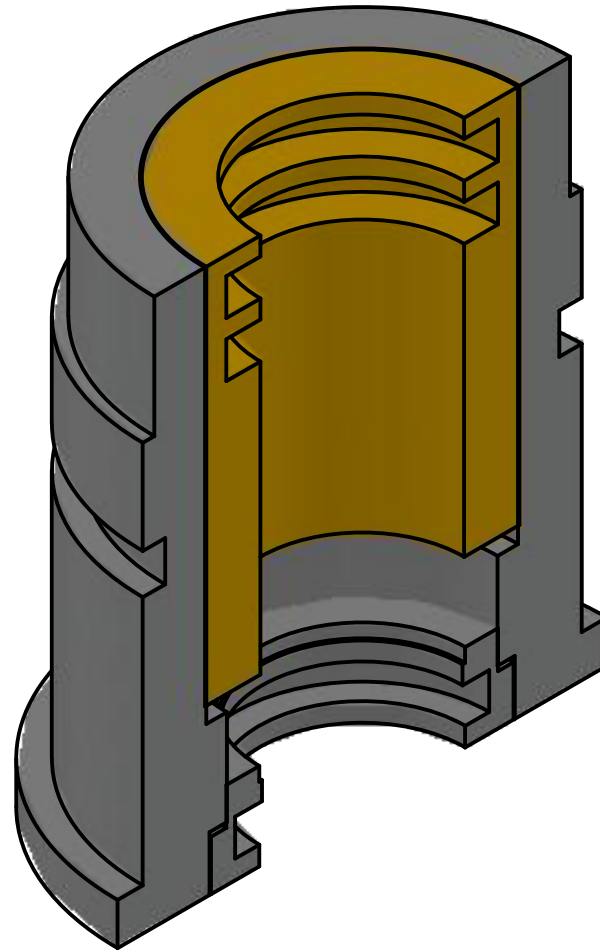
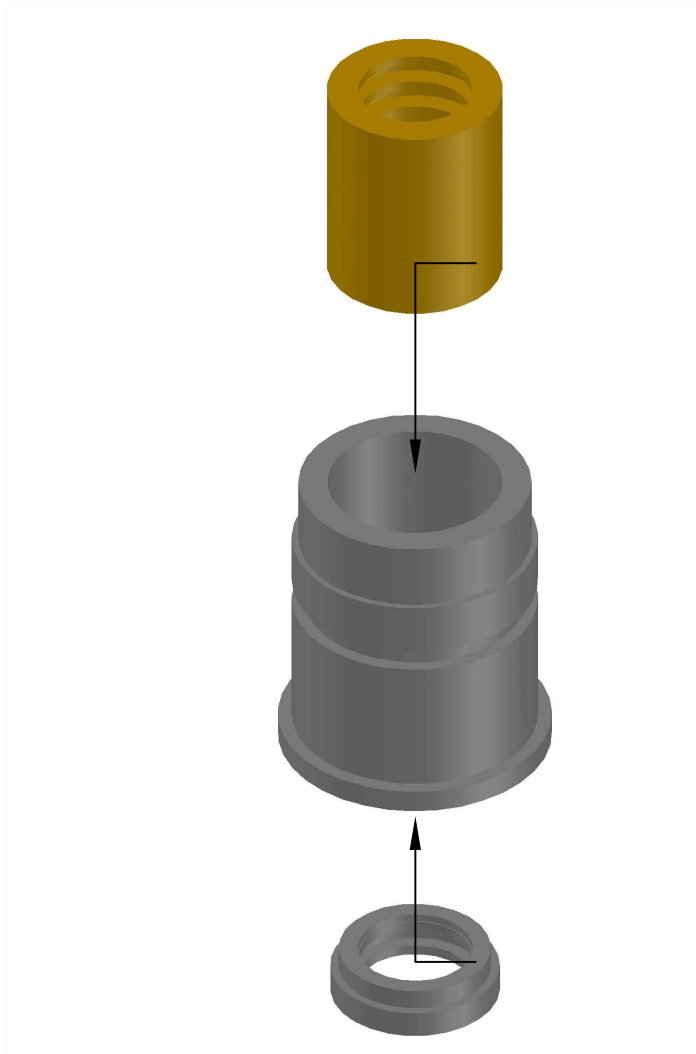

ISOMETRICO

REV.	DESCRIPCIÓN DEL CAMBIO	FECHA	ELABORÓ
1	Emission del plano	27/12/2017	J.LEDESMA



DESCRIPCION DEL EQUIPO
CABEZA DE PISTÓN

CLIENTE:	-----	NO. CLIENTE:	-----
LEVANTAMIENTO:	-----	ELABORO:	J. LEDESMA
COTAS: MM		PROCESO:	MAQUINADO
TOLERANCIAS:		REVISO:	LGOMEZ
X ±		APROBÓ:	ACARRANZA
XX ±			
XXX ±			
XXXX ±			
ANGULAR ± 1°			

CABEZA DE PISTON

ITEM	DESCRIPCIÓN	QTY	MATERIAL	No. PLANO
1	CABEZA DE PISTÓN	1	ACERO AL CARBÓN 10/18	001

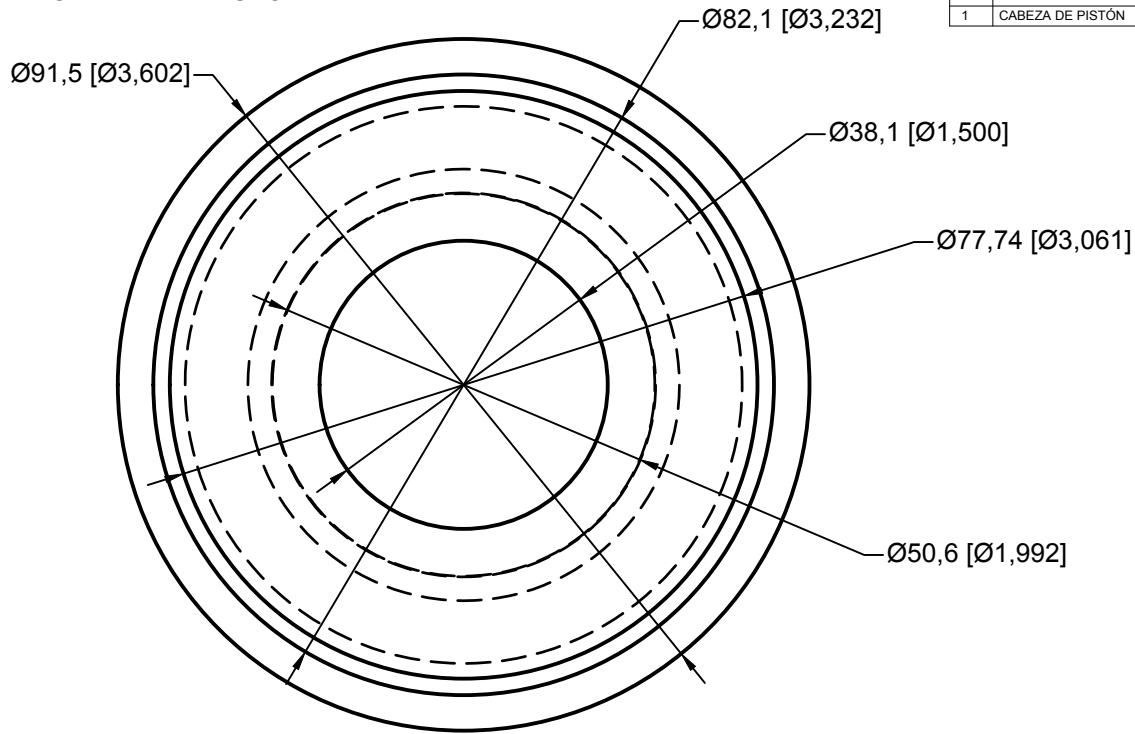

VISTA SUPERIOR

A (1:1)

ACABADO SUPERFICIAL N° 12

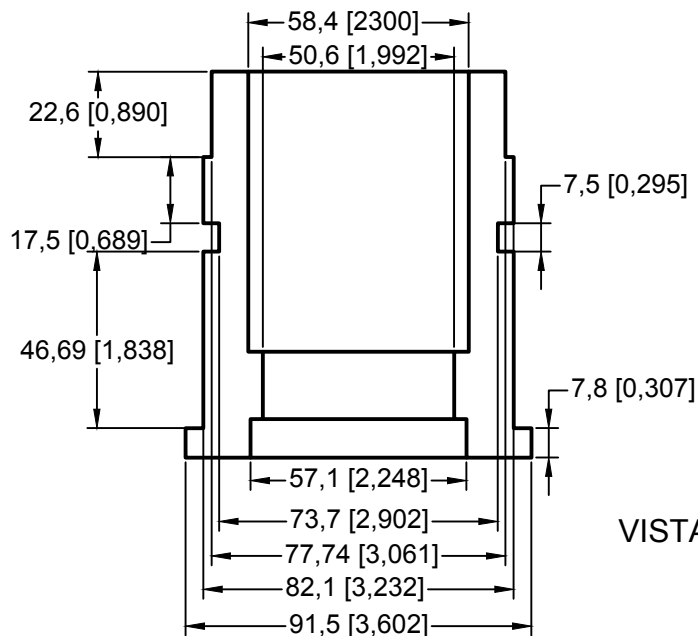
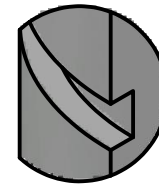

VISTA FRONTAL

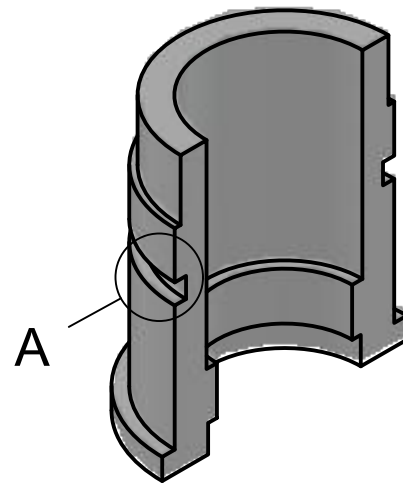

ISOMETRICO

INFORMACIÓN ADICIONAL

ACABADO SUPERFICIAL N° 12

ACABADO SUPERFICIAL N° 2

REV.	DESCRIPCIÓN DEL CAMBIO	FECHA	ELABORÓ
1	Emission del plano	27/12/2017	J.LEDESMA



DESCRIPCION DEL EQUIPO
CABEZA DE PISTÓN

CLIENTE:	-----	
LEVANTAMIENTO:	-----	NO. CLIENTE: -----
COTAS: MM	ELABORO: J. LEDESMA	PROCESO: MAQUINADO
TOLERANCIAS:	REVISO: LGOMEZ	NO. PLANO:
X ±	APROBÓ: ACARRANZA	
XX ±		
XXX ±		
XXXX ±		
ANGULAR ± 1°		

A

B

C

D

E

F

G

H

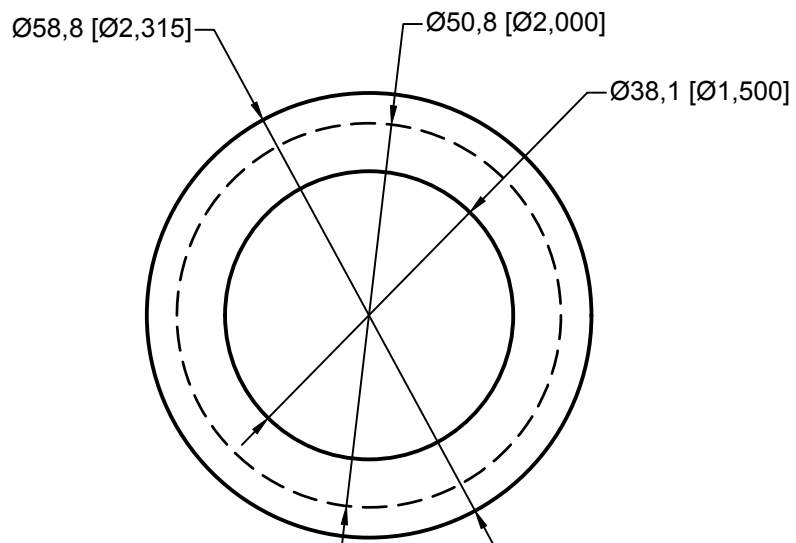

VISTA SUPERIOR

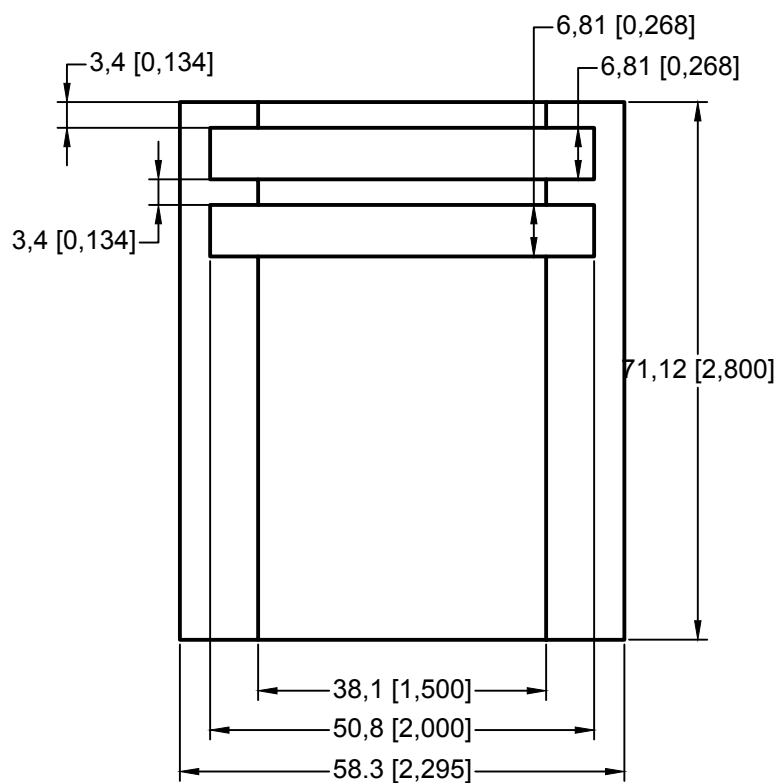

VISTA FRONTAL

ITEM	DESCRIPCIÓN	QTY	MATERIAL	No. PLANO
1	BUJE DE BRONCE	1	BRONCE SAE 64	001

INFORMACIÓN ADICIONAL

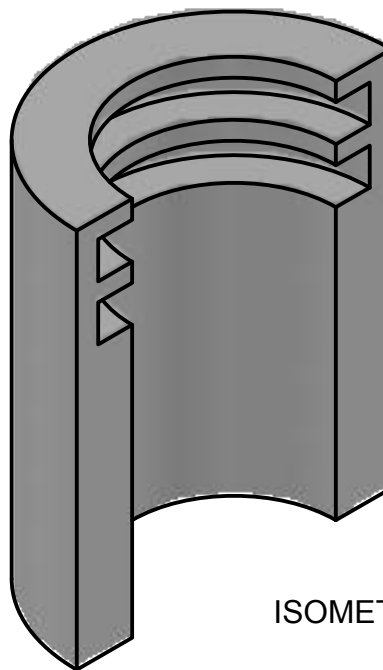

ISOMETRICO

REV.	DESCRIPCIÓN DEL CAMBIO	FECHA	ELABORÓ
1	Emission del plano	27/12/2017	J.LEDESMA



DESCRIPCIÓN DEL EQUIPO
CABEZA DE PISTÓN

CLIENTE:	-----		
LEVANTAMIENTO:	-----	NO. CLIENTE:	-----
COTAS: MM	ELABORO: J. LEDESMA	PROCESO:	MAQUINADO
TOLERANCIAS: X ± XX ± XXX ± XXXX ± ANGULAR ± 1°	REVISO: LGOMEZ	NO. PLANO:	
	APROBÓ: ACARRANZA		

ITEM	DESCRIPCIÓN	QTY	MATERIAL	No. PLANO
1	CABEZA DE PISTÓN	1	ACERO AL CARBÓN 10/18	001

INFORMACIÓN ADICIONAL

ACABADO SUPERFICIAL
N° 12

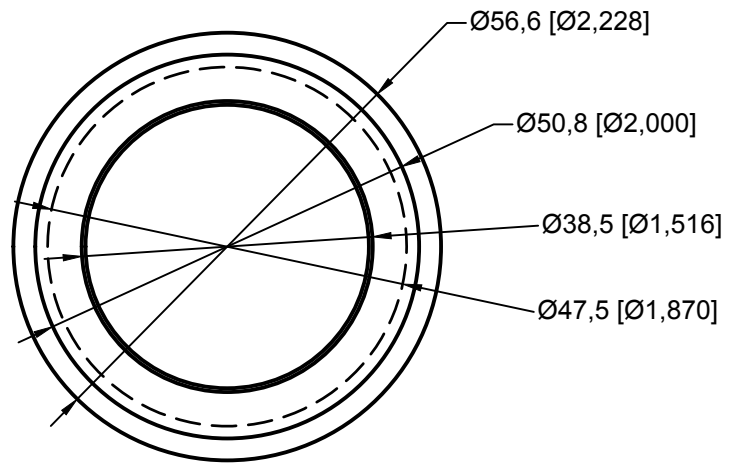

VISTA SUPERIOR

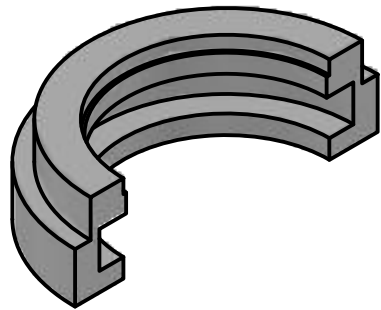

ISOMETRICO

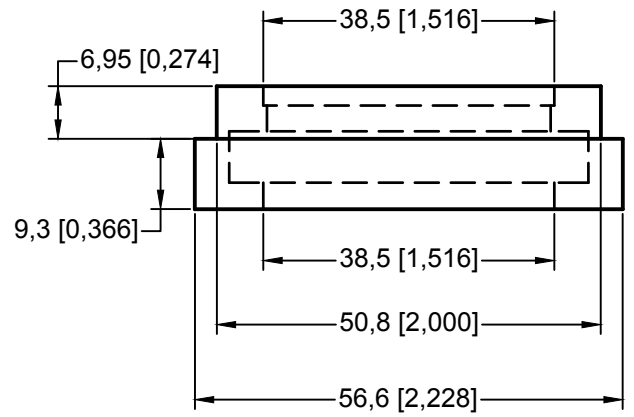

VISTA FRONTAL

REV.	DESCRIPCIÓN DEL CAMBIO	FECHA	ELABORÓ
1	Emission del plano	27/12/2017	J.LEDESMA



DESCRIPCION DEL EQUIPO
CABEZA DE PISTÓN

CLIENTE:		-----
LEVANTAMIENTO:	-----	NO. CLIENTE: -----
COTAS: MM	ELABORO: J. LEDESMA	PROCESO: MAQUINADO
TOLERANCIAS: X ± XX ± XXX ± XXXX ± ANGULAR ± 1°	REVISO: LGOMEZ	NO. PLANO:
	APROBÓ: ACARRANZA	