

**CIVIL WORK**

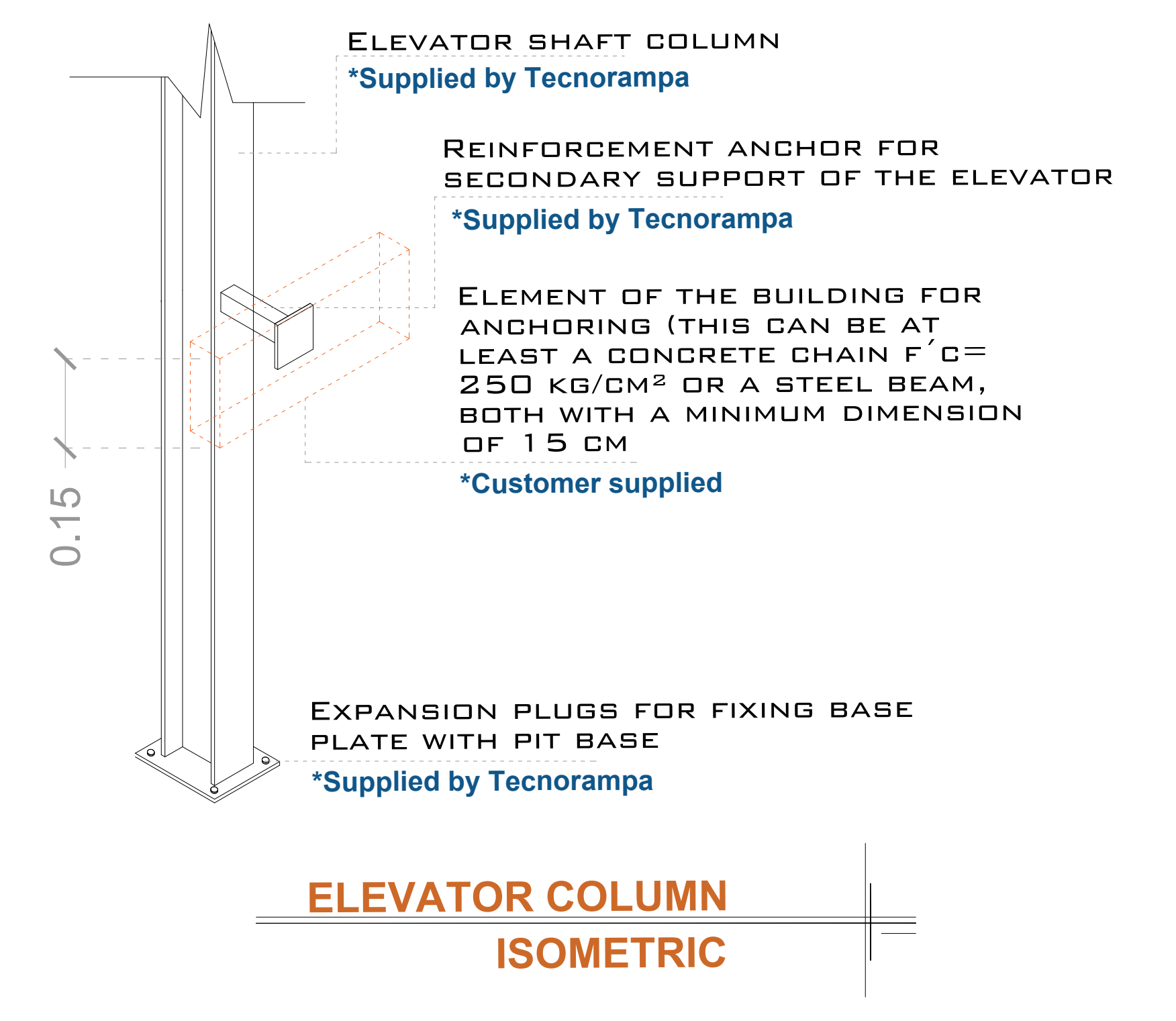
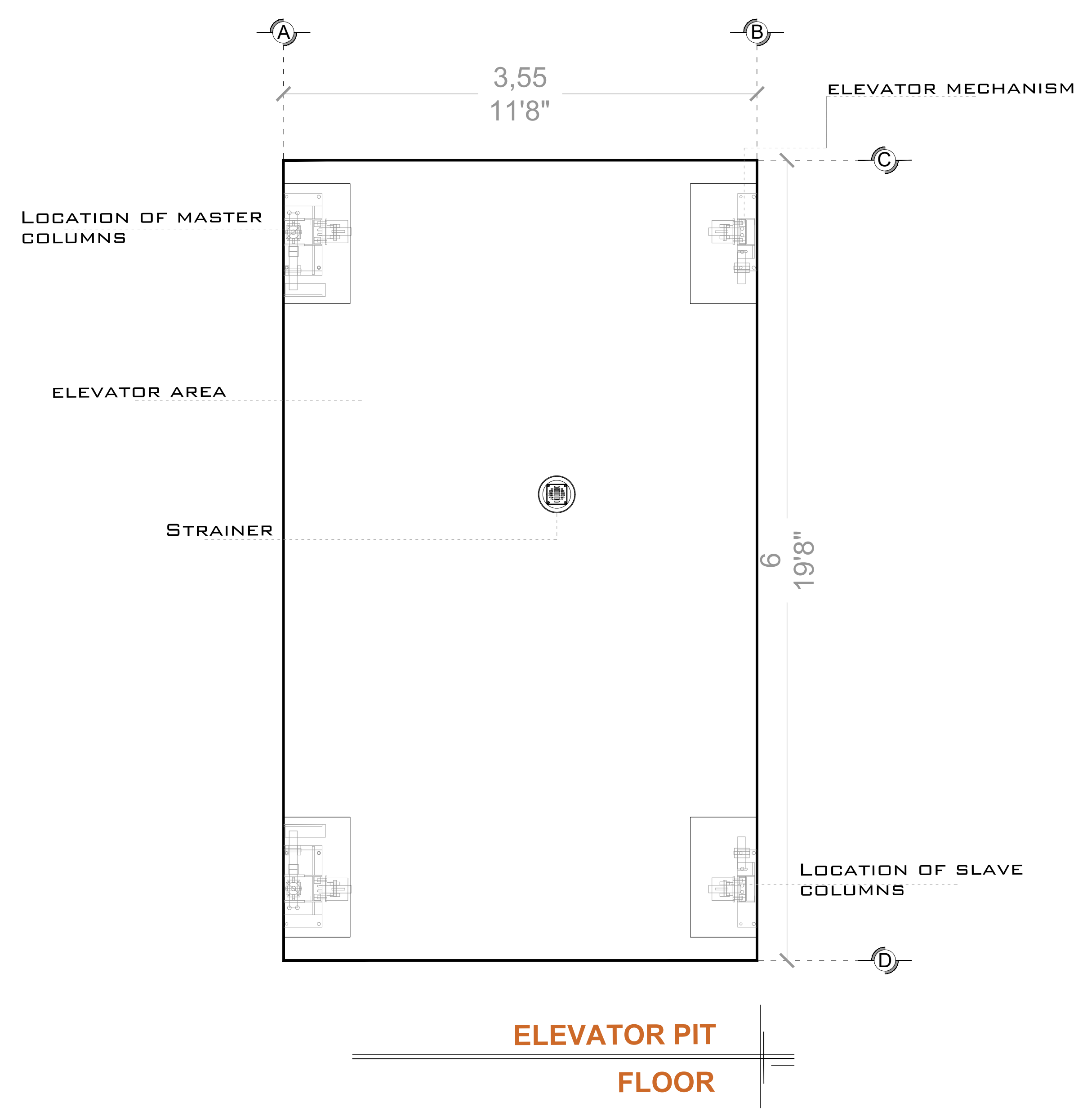
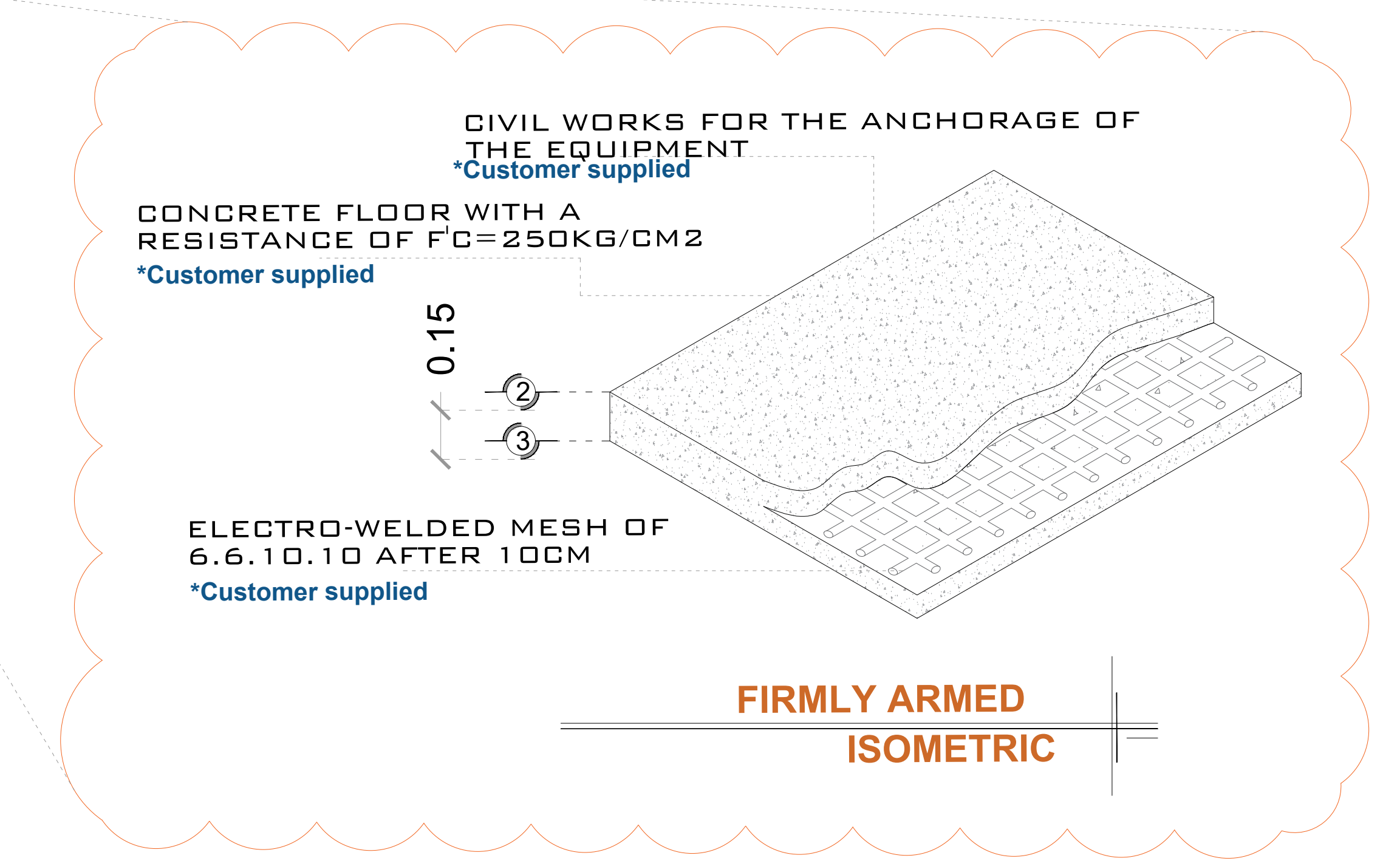
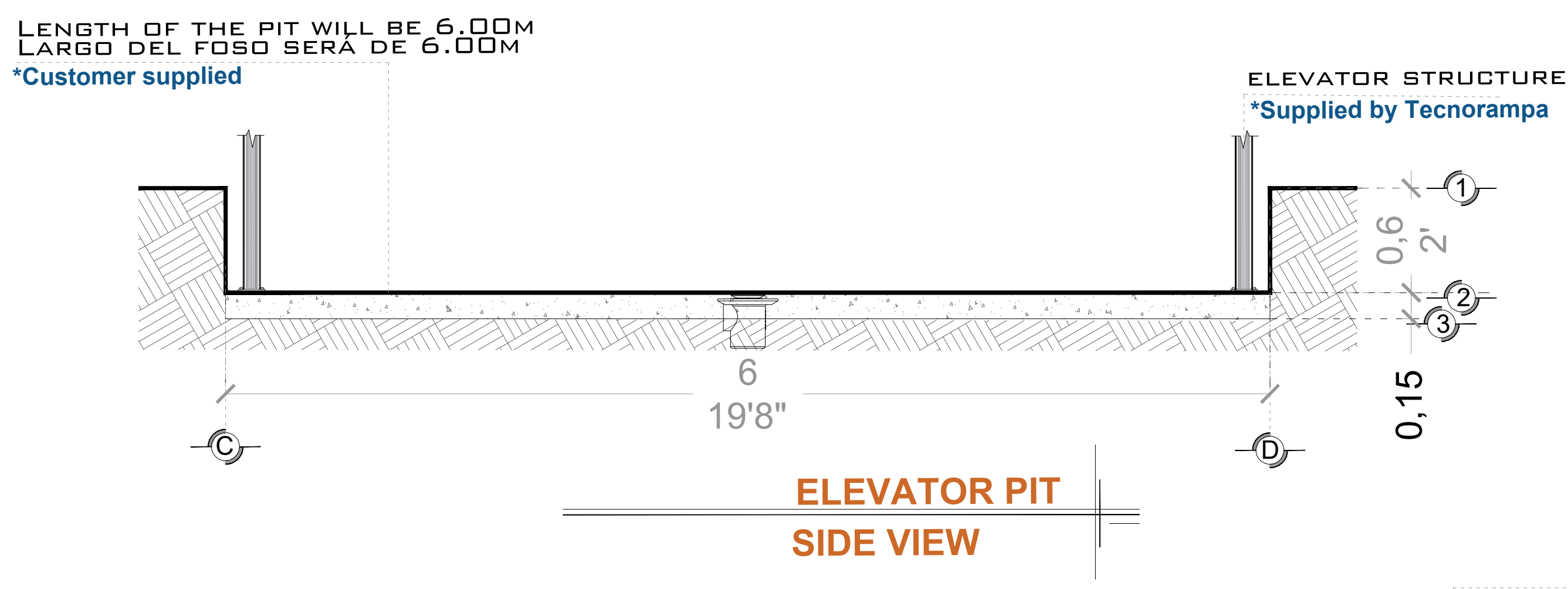
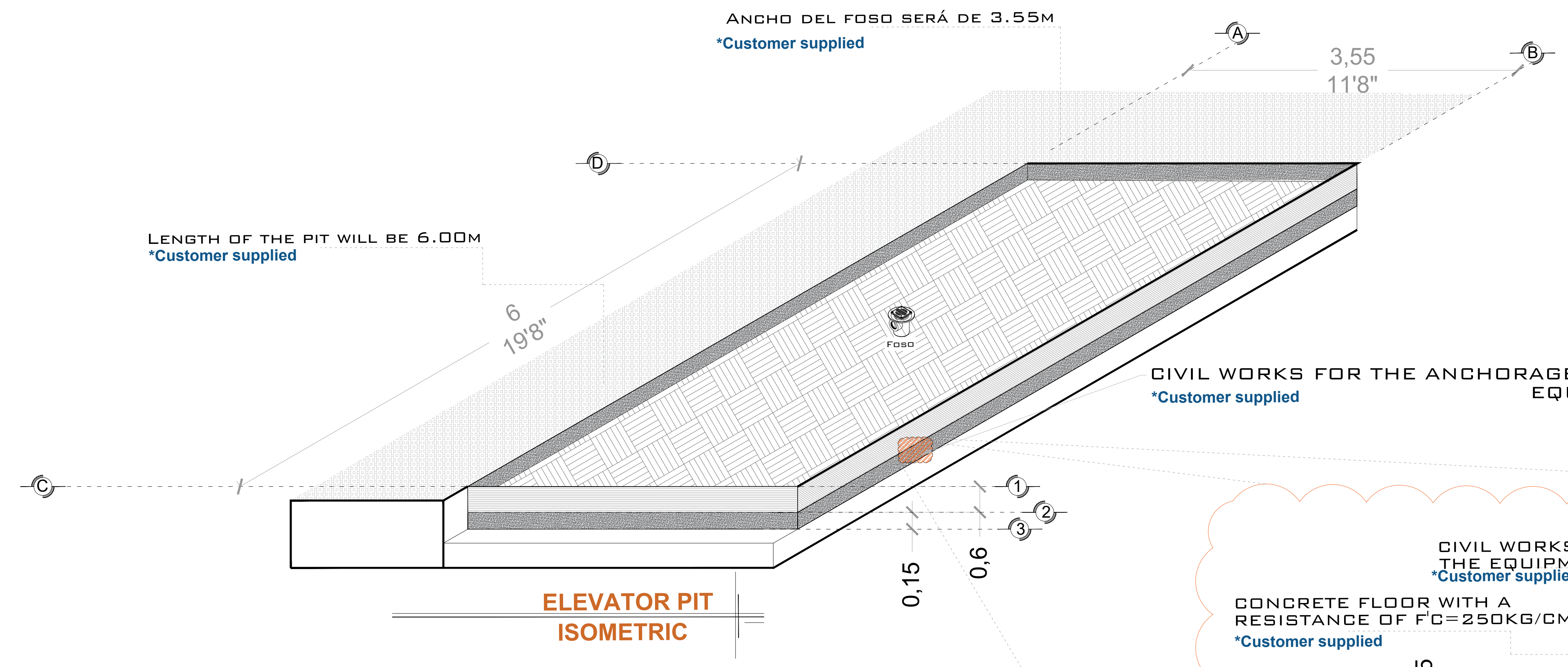
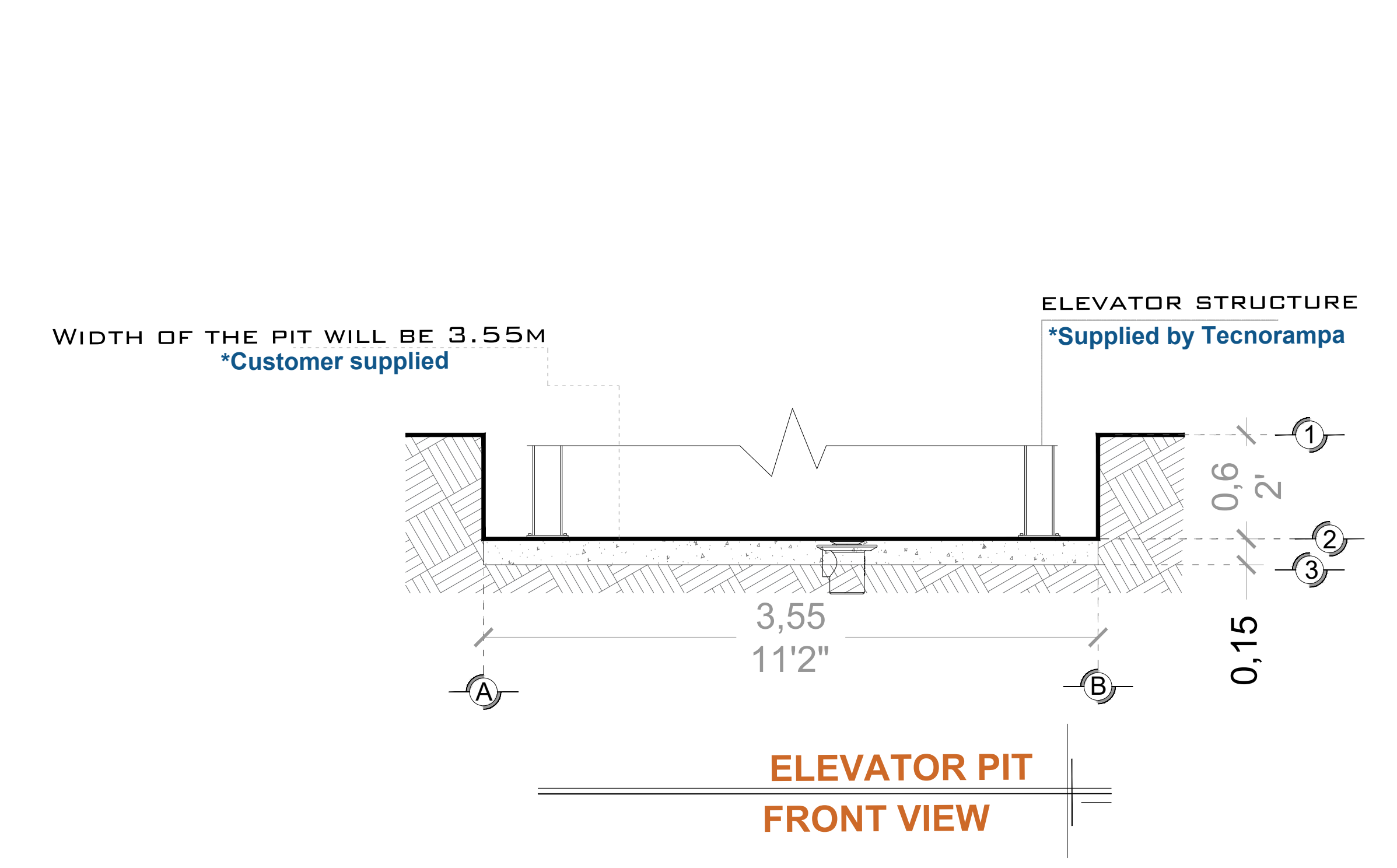

FOR SAFETY REASONS AGAINST POSSIBLE ACCUMULATIONS OF WATER, SUCH AS FLOODS OR LEAKS, IT IS RECOMMENDED TO INSTALL A DRAINAGE PIPE OUTLET (STRAINER) TO DISLodge THE WATER THAT COULD BE STORED IN THE PIT, SAID PIPE WILL BE CONNECTED TO THE DRAINAGE NETWORK OR GREEN AREAS ACCORDING TO THE CLIENT'S DECISION.

- ☞ SIZE PIT WILL MUST MATCH WITH MEZZANINE SIZES AND EACH STATION, KEEPING THE CORRECT LEVELS ON THE PIT FLOOR
- ☞ INSIDE HEIGHT CABIN: 8' (2.44 M)
- ☞ DOUBLE ACCESS
- ☞ NO BUTTON PANELES INSIDE (CABIN)
- ☞ WITH EMERGENCY STOP KEY. GIVE MANY COPIES OF KEYS AT SHIPMENT MOMENT

# FROM CUSTOMER: \_\_\_\_\_

BUSINESS NAME: 2976 3RD AVE BRONX

NAME: 2976 3RD AVE BRONX

LOCATION: \_\_\_\_\_

ELEVATOR : FULL VOX

ELEVATION: 3.66 MTS 12'

No.OF LEVELS: 2

BURDEN: 3500 KG (7700 LBS)

PIPELINE: GROSS

UH : 10 HP

SIGNATURE SELLER: ING. IVAN RICARDO JURY M.

CLIENT'S SIGNATURE:

REVISION	DATE	OBSERVATION
0	19/08/2022	MECHANICAL GUIDE RELEASE
1	27/07/2023	HYDRAULIC DOOR CANCELLED

**TecnoRampa**

**EUA-001-L**

**EQUIPMENT DESCRIPTION**

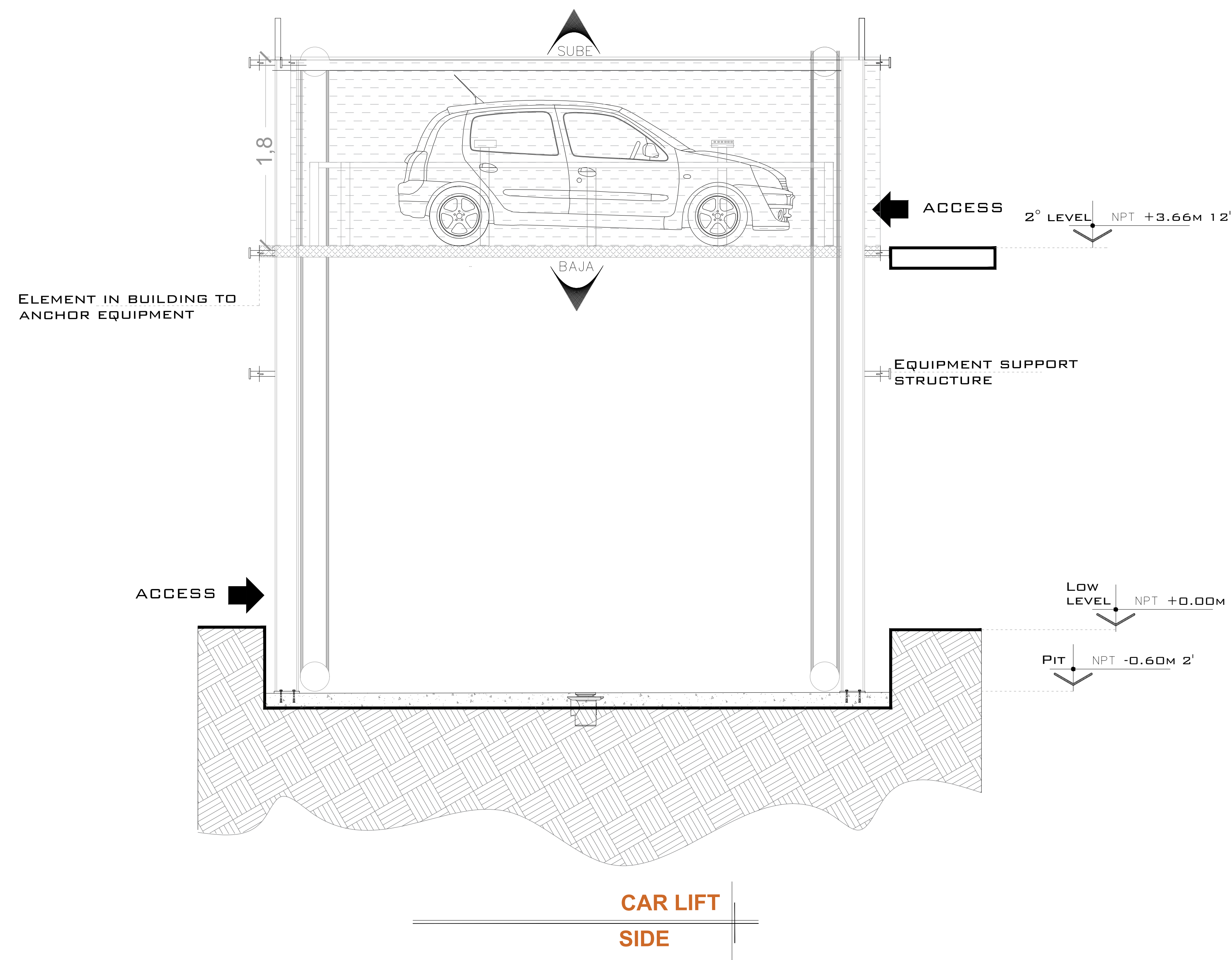

**CAR LIFT SIDE**

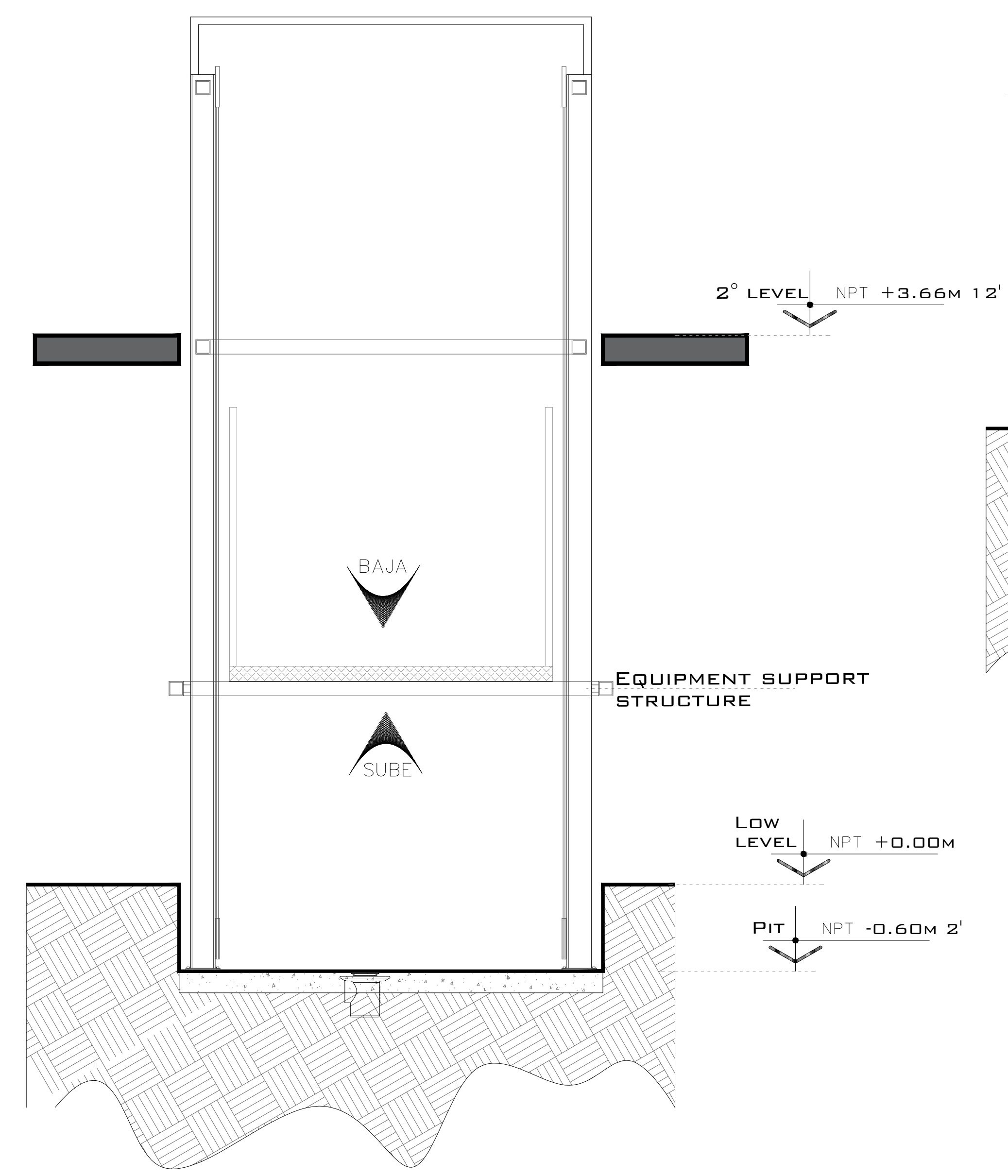

**CAR LIFT FRONTAL**

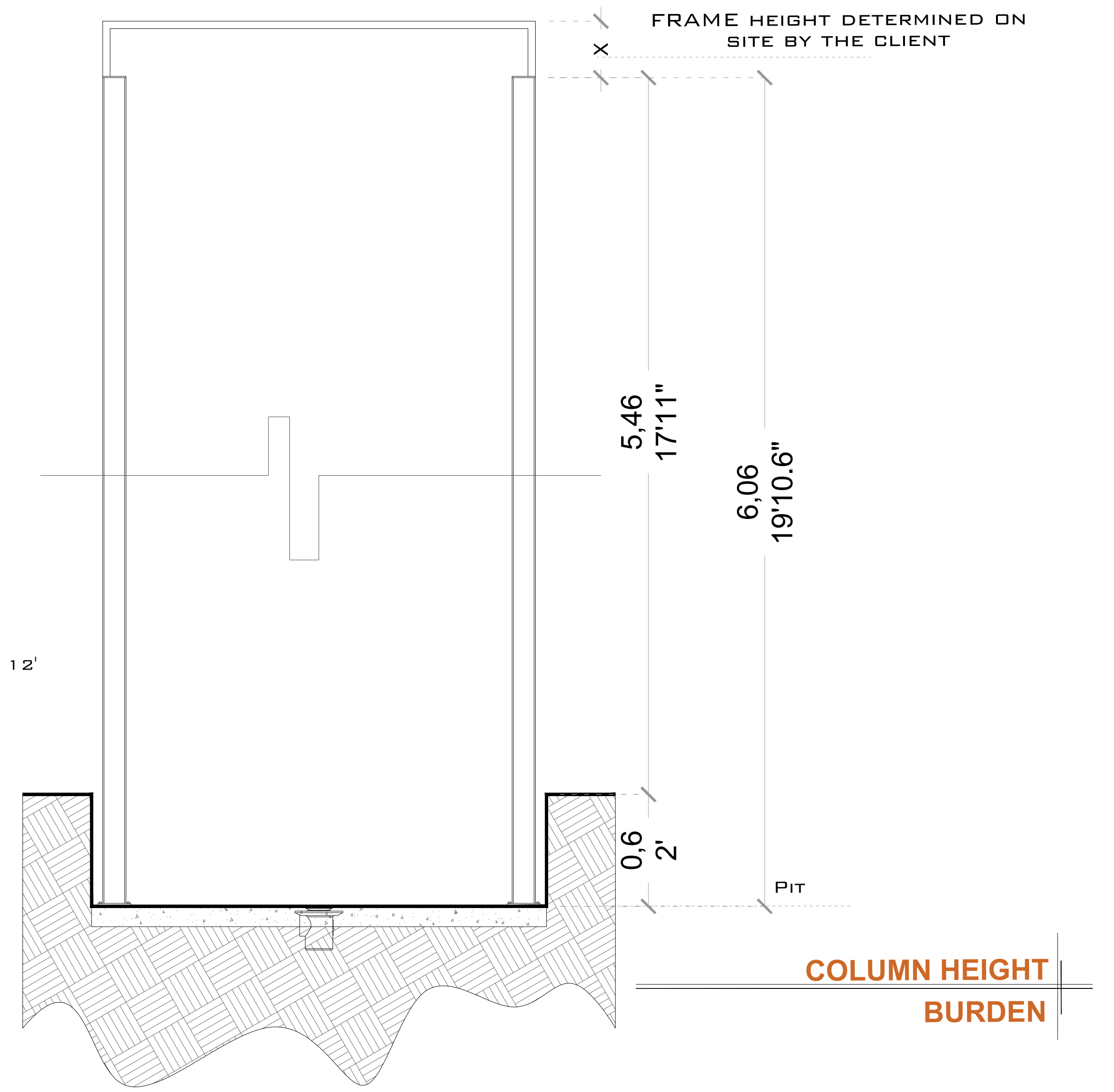

**COLUMN HEIGHT BURDEN**

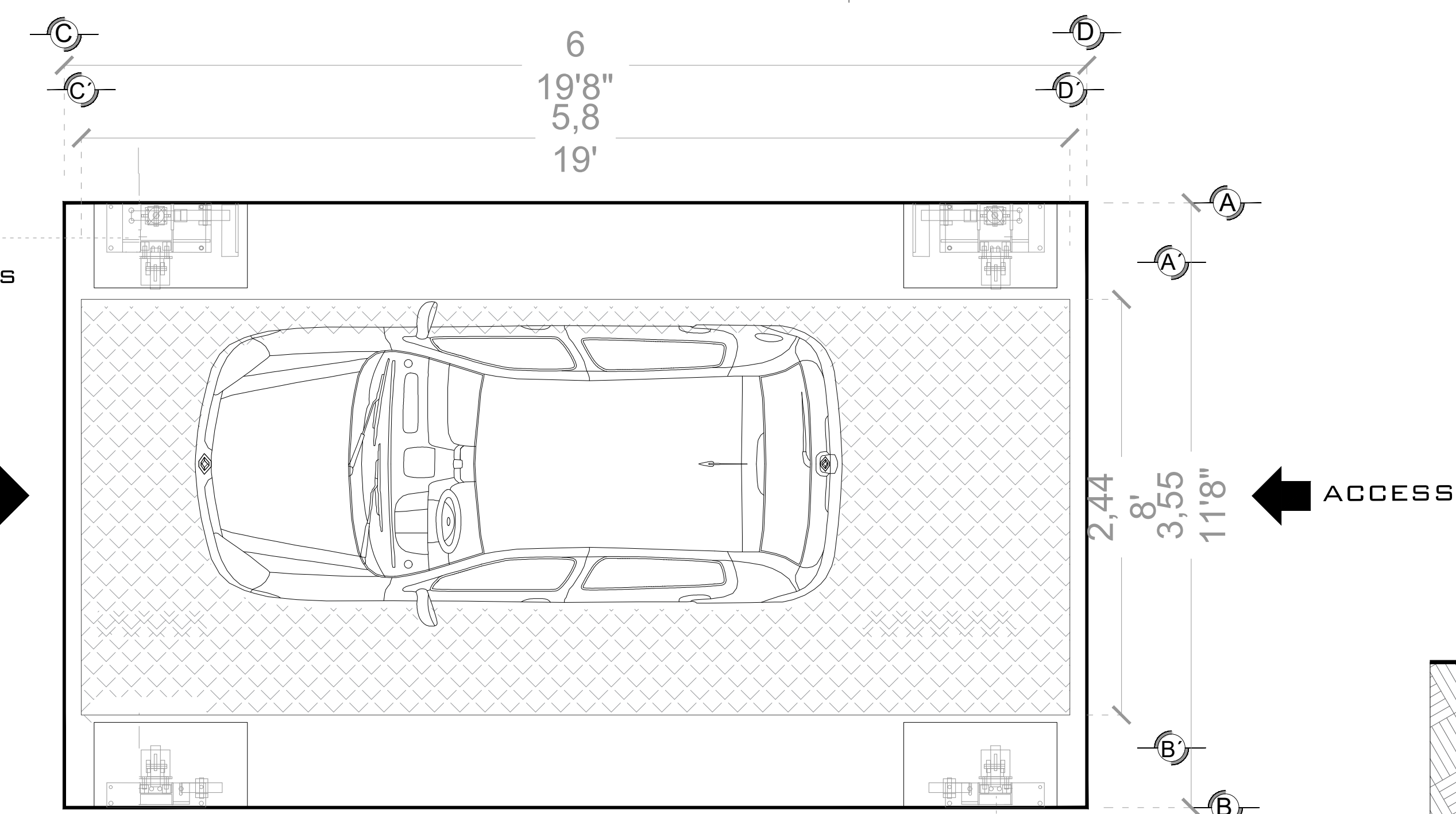

**CAR LIFT FLOOR**

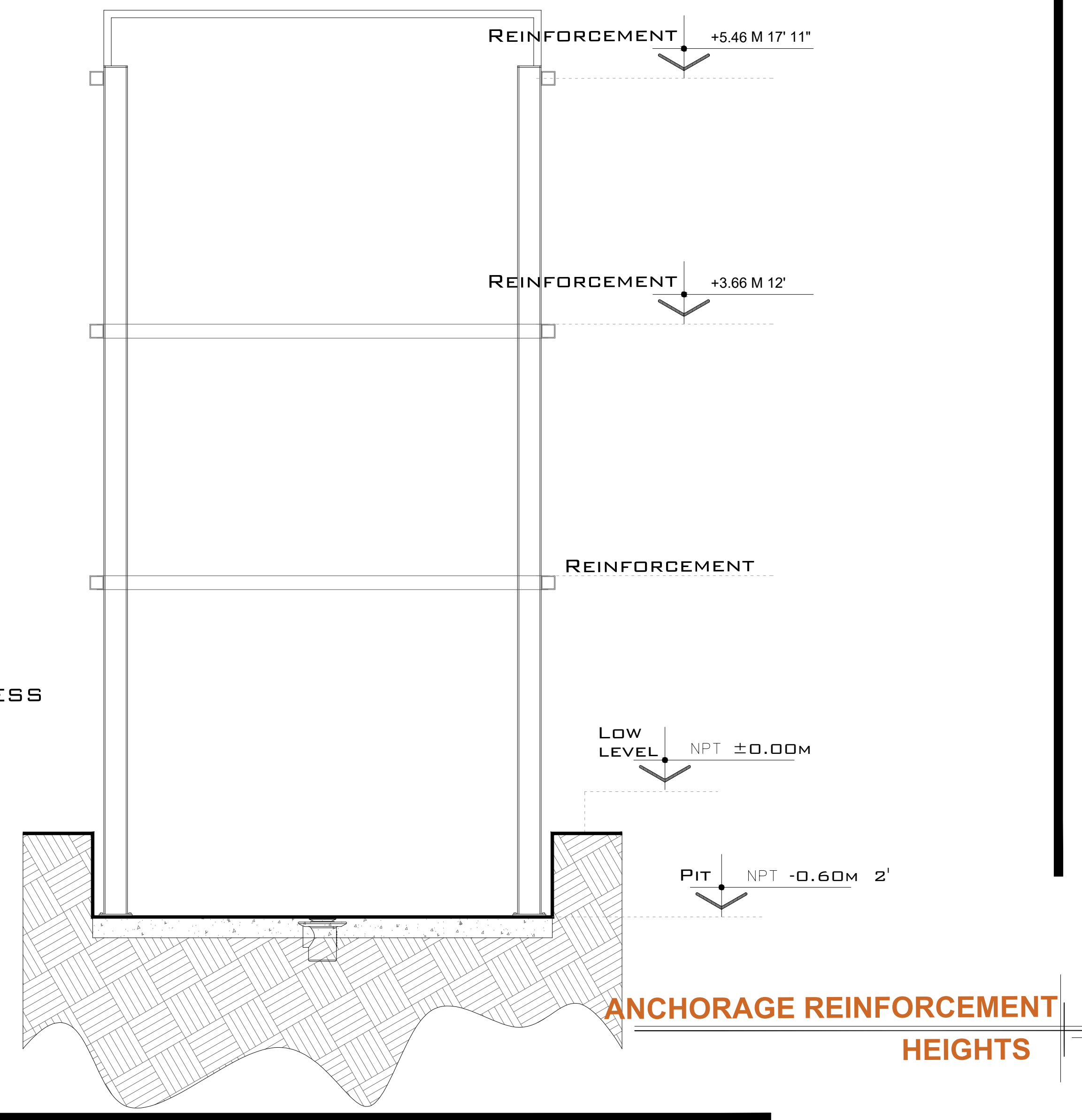

**ANCHORAGE REINFORCEMENT HEIGHTS**

**NOTAS**

- ☞ SIZE PIT WILL MUST MATCH WITH MEZZANINE SIZES AND EACH STATION, KEEPING THE CORRECT LEVELS ON THE PIT FLOOR
- ☞ INSIDE HEIGHT CABIN: 8' (2.45 M)
- ☞ DOUBLE ACCESS
- ☞ -NO BUTTON PANELES INSIDE (CABIN)

# FROM CUSTOMER: \_\_\_\_\_

BUSINESS NAME: 2976 3RD AVE BRONX

NAME: 2976 3RD AVE BRONX

LOCATION: \_\_\_\_\_

ELEVATOR: VOX

ELEVATION: 3.66 MTS 12'

No.OF LEVELS: 2

BURDEN: 3500 KG (7700 LBS)

PIPELINE: GROSS

UH: 10 HP

SIGNATURE SELLER: ING. IVAN RICARDO JURY M.

CLIENT'S SIGNATURE:

REVISION	DATE	OBSERVATION
0	19/08/2022	MECHANICAL GUIDE RELEASE
1	27/07/2023	HYDRAULIC DOOR AND BUTTON PANEL CANCELLED

**TecnoRampa**

**EUA-002-L**

**EQUIPMENT**

# HYDRAULIC UNIT

FOR THE OPERATION OF THE ELEVATOR, A HYDRAULIC UNIT IS NECESSARY, WHICH IS NOT CONTEMPLATED WITHIN THE CLEARING OF THE ELEVATOR, THE OPTION IS GIVEN TO THE CLIENT WHO DECIDES THE PLACE OF THE UNIT. IT IS REQUIRED TO PLACE A NICHE TO HOUSE THE HYDRAULIC UNIT AND THE ELECTRICAL CONTROL, HAVING ACCESS FOR MAINTENANCE.

THE HYDRAULIC UNIT AND ELECTRICAL CONTROL MUST BE INSTALLED AND LOCATED IN A PLACE FREE OF DUST, LIQUIDS AND INCLEMENT WEATHER, AVOIDING CONTAMINATION OF THE OIL AND LOSS OF THE EQUIPMENT WARRANTY.

THE ROUTE OF THE TUBING SHOULD NOT BE GREATER THAN 5.00 LINEAR METERS

LOAD CENTER WITH THREE-PHASE POWER SUPPLY AT 220V, WITH NEUTRAL AND PHYSICAL GROUND WITH 3X40AMP THERMOMAGNETIC PROTECTION SWITCH, EXCLUSIVE FOR THE ELEVATOR

- CABLE GAUGE 8 AWG FOR DISTANCES UP TO 10.00M.
- GAUGE 6 AWG FOR DISTANCES UP TO 15.00M.
- FOR DISTANCES GREATER THAN 15.00M, CONTEMPLATE THE CALCULATION OF CURRENT TO AVOID VOLTAGE DROP

COMPLETELY STRAIGHT DUCT OF Ø 3" FOR CHANNELING THE HYDRAULIC SYSTEM.

FOR SECURITY, IT SHOULD NOT BE MANIPULATED BY UNAUTHORIZED PERSONNEL.

BY IGNORING THE INDICATIONS ALREADY DICTATED AND THE EQUIPMENT HAS A FAULT, TECNORAMPA WILL NOT BE RESPONSIBLE FOR THESE, IN ADDITION TO THE FACT THAT THE GUARANTEE YEAR WOULD NOT COVER THESE DAMAGES.

## NOTE:

- ☞ SIZE PIT WILL MUST MATCH WITH MEZZANINE SIZES AND EACH STATION, KEEPING THE CORRECT LEVELS ON THE PIT FLOOR
- ☞ INSIDE HEIGHT CABIN: 8' (2.45 M)
- ☞ DOUBLE ACCESS
- ☞ -NO BUTTON PANELES INSIDE (CABIN)

LOUVER DOOR FOR EQUIPMENT PROTECTION

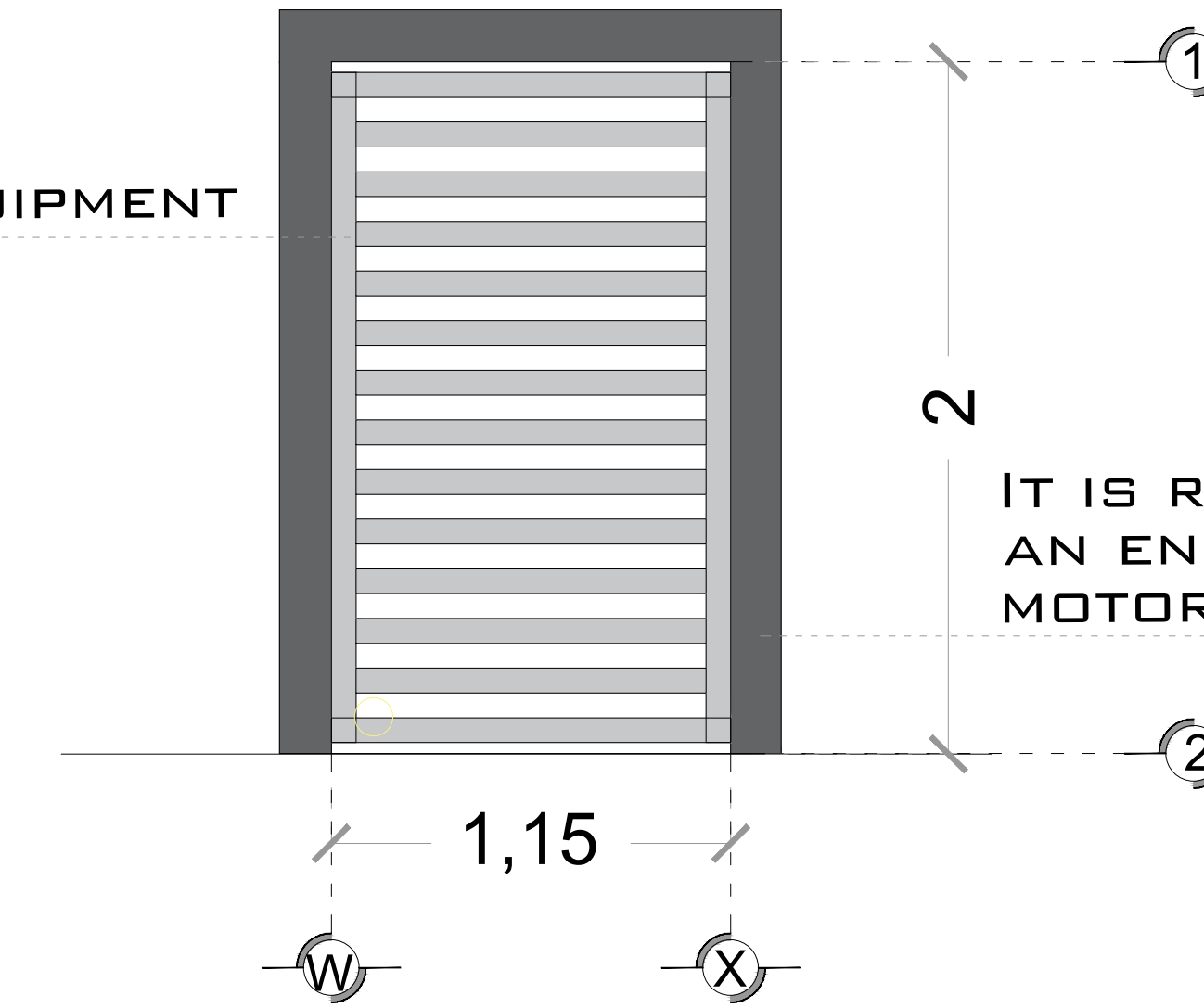

IT IS RECOMMENDED TO PLACE AN ENCLOSURE TO PROTECT THE MOTOR FROM THE ELEMENTS.

DESCRIPTION OF HYDRAULIC UNIT CABINET (FRONT VIEW)

HYDRAULIC UNIT DESCRIPTION	
HYDRAULIC UNIT	10HP
ALIMENTATION	220 VCA
NUMBER OF PHASES	3
CONSUMPTION AMPERES	27
CONSUMPTION WATTS	7.4 KW
TYPE OF OIL	ISO 68

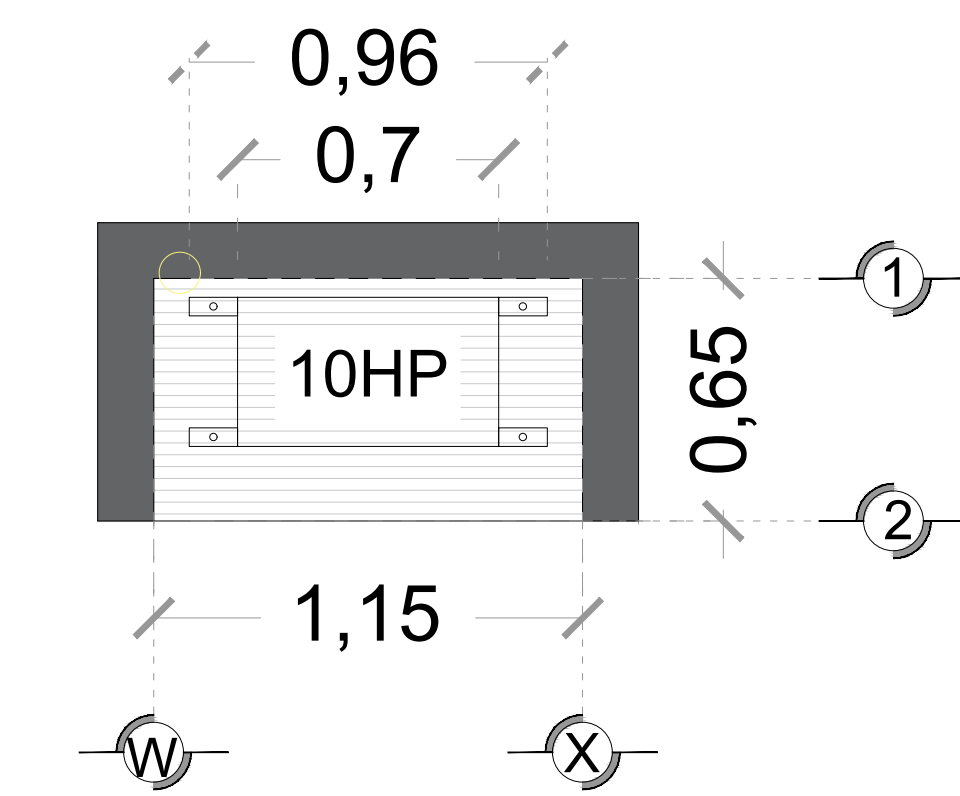

DESCRIPTION OF HYDRAULIC UNIT CABINET (FLOOR VIEW)

HYDRAULIC UNIT 10 HP

VARIATION RANGE POWER FOR 10 HP MOTOR VOLTAGE: 230 VAC +-8%

# FROM CUSTOMER: \_\_\_\_\_  
 BUSINESS NAME: 2976 3RD AVE BRONX  
 NAME: 2976 3RD AVE BRONX  
 LOCATION: \_\_\_\_\_  
 ELEVATOR : VOX

ELEVATION: 3.66 MTS 12'  
 No.OF LEVELS: 2  
 BURDEN: 3500 KG (7700 LBS)  
 PIPELINE: GRUESA  
 UH : 10 HP

SIGNATURE SELLER: ING. IVAN RICARDO JURY M.

CLIENT'S SIGNATURE: \_\_\_\_\_

REVISION	DATE	OBSERVATION
0	19/08/2022	MECHANICAL GUIDE RELEASE
1	27/07/2023	HYDRAULIC DOOR AND BUTTON PANEL CANCELLED

**TecnoRampa**

EUA-003-L

ELECTROHYDRAULIC

## ELEVATOR SAFETY

- SAFETY MECHANISMS IN ELEVATORS ARE A FUNDAMENTAL PART OF THE PLACEMENT AND START-UP OF OUR EQUIPMENT.
- THUS, EVERY TIME AN ELEVATOR IS USED, TAKE INTO ACCOUNT SOME BASIC POINTS.
- DO NOT PUT YOUR HANDS, FEET, HEAD, OR ANY OBJECT OUT OF THE ELEVATOR, WHEN IT IS IN OPERATION.
- DO NOT OPERATE THE LIFT WHEN THERE IS A HYDRAULIC FAILURE.
- RESPECT THE INDICATIONS WITHOUT EXCEEDING ITS WEIGHT CAPACITY.
- DO NOT OPERATE THE EQUIPMENT WITHOUT FIRST HAVING BEEN DELIVERED BY A TECNORAMPA SPECIALIST.
- NEVER USE THE LIFT IN CASE OF FIRE.
- DO NOT OPERATE THE LIFT IF THE STEEL CABLES ARE FRAKED.

## INSTALLATION REQUIREMENTS

THE PIT WILL BE IN OPTIMAL CONDITIONS (NO PUDDLES INSIDE THE PIT, AREA FREE OF ANY OBJECTS OR MATERIALS UNDER CONSTRUCTION, FREE ACCESS TO TRANSPORT THE EQUIPMENT TO THE INSTALLATION AREA)

FOR THE INSTALLATION OF THE ELEVATOR, IT IS NECESSARY TO HAVE 220V POWER TO CONNECT A WELDING MACHINE, TO 2 PHASES AND IT MUST HAVE A CONSUMPTION CAPACITY OF 60 AMP. FREE. IF THIS POWER SUPPLY IS NOT AVAILABLE, THE LIFT CANNOT BE INSTALLED ON THE AGREED DATE. AND A NEW AVAILABLE INSTALLATION DATE WILL BE GIVEN, ACCORDING TO OUR INSTALLATION SCHEDULE.

THE CIVIL WORK REQUIRED BY TECNORAMPA MUST BE READY ON THE AGREED DATE SO AS NOT TO RESCHEDULE THE INSTALLATION OF THE EQUIPMENT.

CONSIDER ACCESS FOR OUR TECNORAMPA EQUIPMENT, SINCE THESE ARE ARMED AND IF THERE IS NO SPACE TO ACCESS WITHOUT INCONVENIENCE, DISCUSS THIS WITH YOUR DESIGNATED VENDOR AND THUS TAKE THE NECESSARY PRECAUTIONS.

## EQUIPMENT SPECIFICATIONS

- ARMED TEAM
- FULL COLUMNS
- ESTRUCTURE EQUIPEMENT COLOR: BLACK
- FINISHED: SILVER ALUCOBOND PANELS
- 2 HYDRAULIC DOOR

## ADDITIONAL COMPONENTS FOR THE TEAM

- BUTTON PANELS CHANNELED BY TECNORAMPA.
- DOUBLE ACCESS
- NO BUTTON PANELES INSIDE (CABIN)

### NOTE

- SIZE PIT WILL MUST MATCH WITH MEZZANINE SIZES AND EACH STATION, KEEPING THE CORRECT LEVELS ON THE PIT FLOOR
- INSIDE HEIGHT CABIN: 8' (2.45 M)
- DOUBLE ACCESS
- NO BUTTON PANELES INSIDE (CABIN)
- WITH EMERGENCY STOP KEY. GIVE MANY COPIES OF KEYS AT SHIPMENT MOMENT

# FROM CUSTOMER: \_\_\_\_\_  
 BUSINESS NAME: 2976 3RD AVE BRONX  
 NAME: 2976 3RD AVE BRONX  
 LOCATION: \_\_\_\_\_  
 ELEVATOR : VOX

ELEVATION: 3.66 MTS 12'  
 No.OF LEVELS: 2  
 BURDEN: 3500 KG (7700 LBS)  
 PIPELINE: GROSS  
 UH : 10 HP

SIGNATURE SELLER: ING. IVAN RICARDO JURY M.

CLIENT'S SIGNATURE: 

REVISION	DATE	OBSERVATION
0	19/08/2022	MECHANICAL GUIDE RELEASE
1	27/07/2023	HYDRAULIC DOOR CANCELLED

**TecnoRampa**

EUA-004-L

ADDITIONAL FEATURES

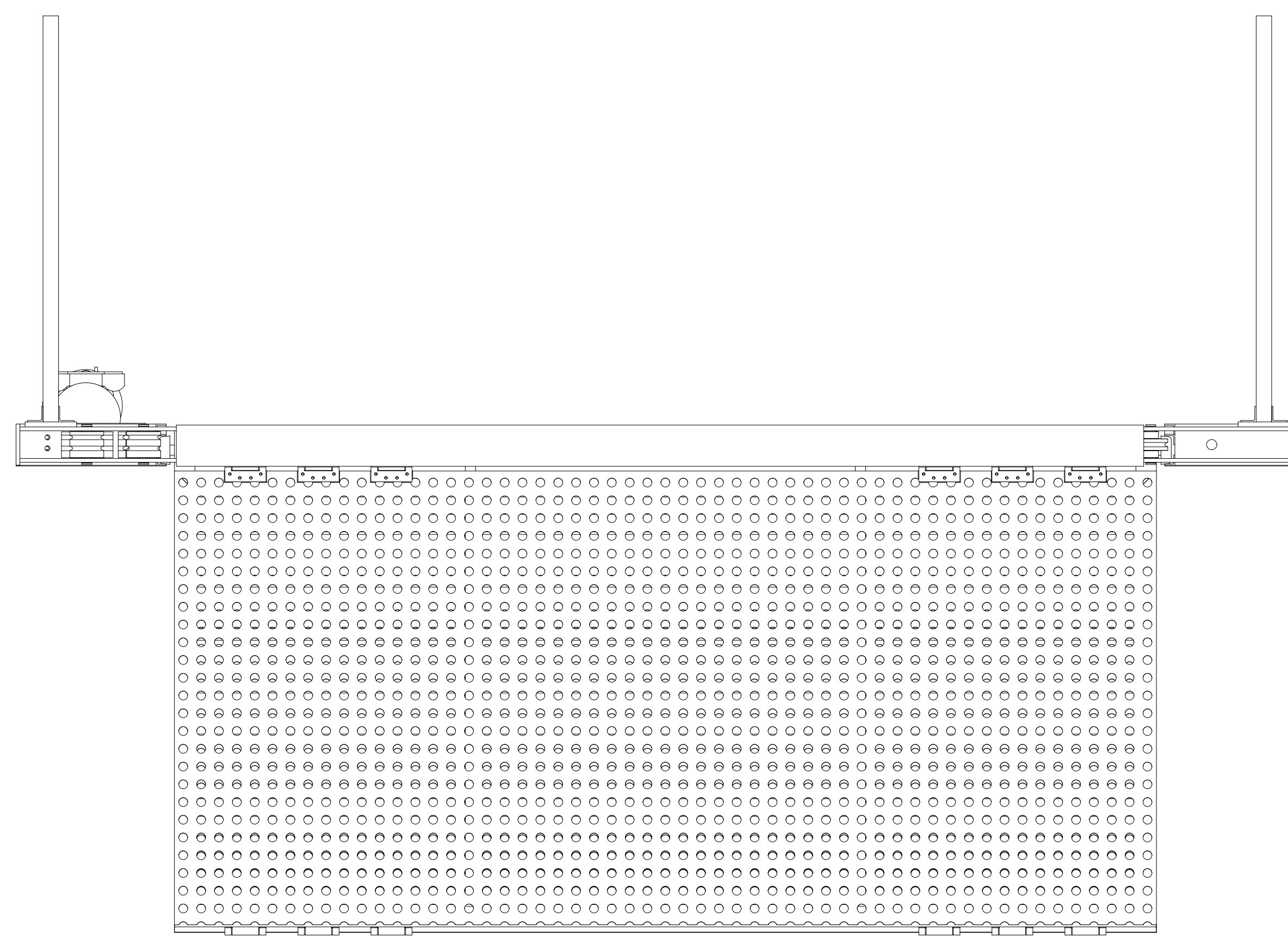

HYDRAULIC DOOR  
FLOOR PLAN

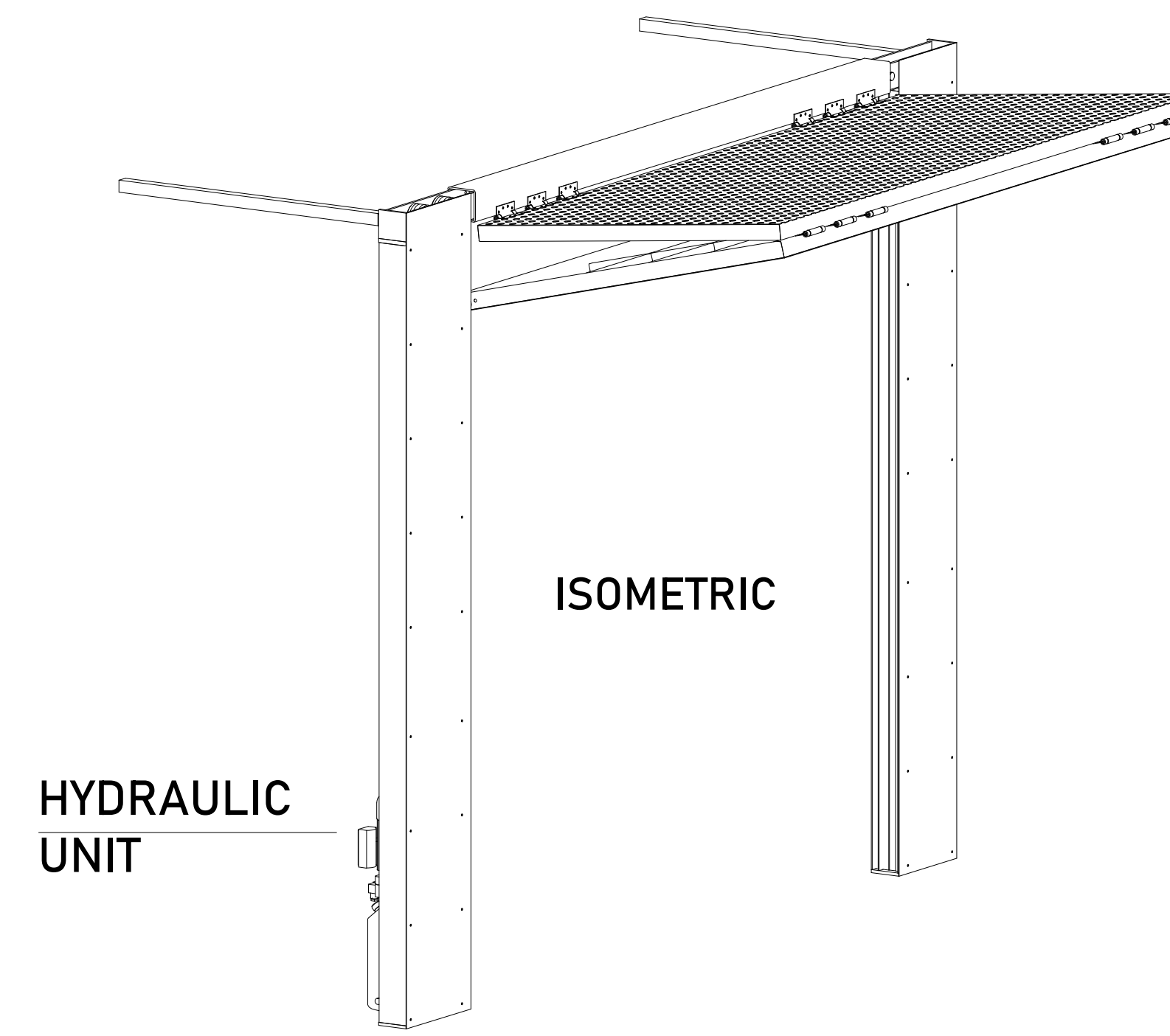

HYDRAULIC  
UNIT

ISOMETRIC

DESCRIPTION H.U. 2 HP	
POWERED	110 VCA
NUMBER PHASES	1
AMPERS	18.5
WATSS	1.5 KW
OIL TAPE	ISO 68

CALIBER DATA	
CALIBER	DISTANCE
8 AWG	0-10M
6 AWG	11-15 M
CALCULATING	16- EN ADELANTE

REFERENCE:  
VARIATION RANGE POWER FOR  
3 HP MOTOR: 220 VAC +- 5%

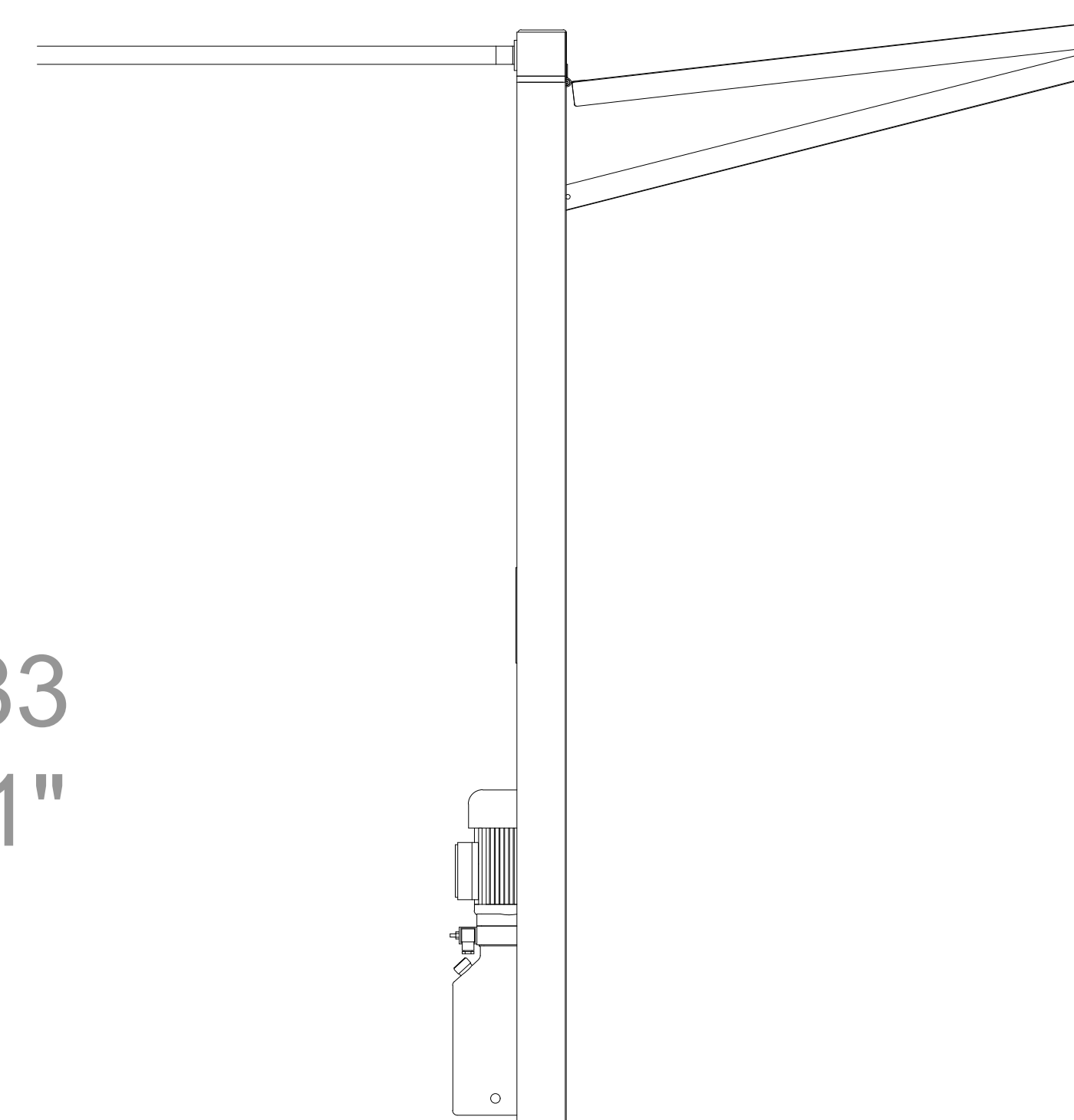
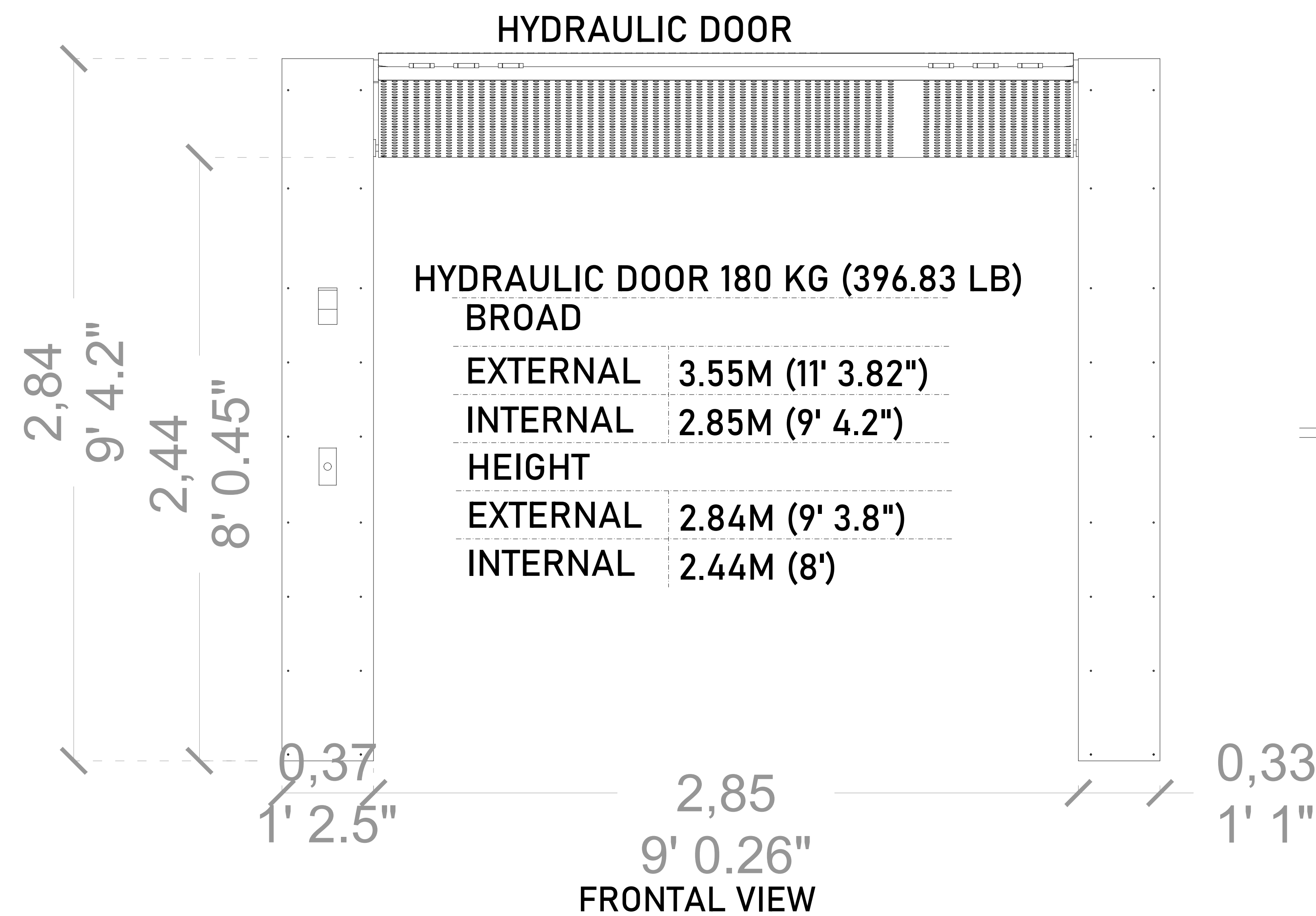

SIDE VIEW

**1 HYDRAULIC DOOR**

- MAXIMUM LOAD CAPACITY FOR FINISHES OF 180 KG.
- 2HP MOTOR, 110 VAC POWERED SUPPLY, NEUTRAL AND EARTH GROUND.
- WIRING CONNECTION FOR BUTTON PANEL MUST MATCH WITH THE U.H.
- PERFORATED SHEET FINISH.
- A FREE HEIGHT OF 2.90M IS NECESSARY ON SITE FOR THE INSTALLATION OF THE HYDRAULIC DOORS.

NOTE: THE DOOR IS FIXED TO THE STRUCTURE OF THE ELEVATOR AND IT IS FIXED TO THE FLOOR WITH STUDS

**NOTES**

- SIZE PIT WILL MUST MATCH WITH MEZZANINE SIZES AND EACH STATION, KEEPING THE CORRECT LEVELS ON THE PIT FLOOR
- INSIDE HEIGHT CABIN: 8' (2.44 M)
- DOUBLE ACCESS
- NO BUTTON PANELES INSIDE (CABIN)
- WITH EMERGENCY STOP KEY. GIVE MANY COPIES OF KEYS AT SHIPMENT MOMENT

# DE CLIENTE: \_\_\_\_\_

RAZON SOCIAL: 2976 3RD AVE BRONX

NOMBRE: 2976 3RD AVE BRONX

UBICACIÓN: \_\_\_\_\_

ELEVADOR : VOX

ELEVACION: 3.66 MTS 12'

No. DE NIVELES 2

CARGA: 3500 KG (7700 LBS)

TUBERÍA: GRUESA

UH : 10 HP

VENDEDOR FIRMA: ING. IVAN RICARDO JURY M.

FIRMA DEL CLIENTE: \_\_\_\_\_

REVISIÓN	FECHA	OBSERVACIÓN
0	19/08/2022	LIBERACION DE GUIA MECANICA
1	27/07/2023	SE OMITEN BOTONERAS INTERIORES

**TecnoRampa**

EUA-005-L

EXTRAS